



**To improve the combustion and to reduce the fuel**

**waste in engines**

Following the scientific effects of an intense magnetic field we have realized the SUPER CATALYZER for endothermic engines (motorcycles, cars, buses, trucks, lorries, generally all the heavy means ).

It reduces the fuel waste, improve the power, does not allow the forming of encrustations in the engine obtaining a cleaning action, and reducing considerably the emission of toxic substances from exhaust pipe.

It can be set on petrol engines, diesel, any kind of gas, electric connection not requested.

Produced by

**vosges** <sup>®</sup> <sup>™</sup>  
**Future technology**

### **Experimental technical data**

- ▶ Cut of fuel waste up to about 10%
- ▶ Reduction of atmospheric pollution up to about 80%
- ▶ No replacement or maintenance of SUPER CATALYZER
- ▶ It works with all kinds of fuel and engine, with the turbocharger it maintains the turbines always in the maximum efficiency.
- ▶ It cleans the valves, the combustion chambers, the exhaust manifolds, avoiding the presence of oily wastes and paraffin encrustations.
- ▶ The start in diesel engines, also with temperatures plenty below zero, is highly easier.
- ▶ For the residual fumes, it gives performances like those obtained with the better catalytic exhaust, with no operating costs and a lot hp more.

### **Working principles**

Basicly it is a permanent magnetic field at high level (10.000 Gauss), and crossing it the fuel molecules are compressed, sustaining a violent acceleration. Said speed increase implies in molecules an increase of temperature, promoting a quick vaporisation of the fuel inside of the engine, producing consequently a higher inflammability.

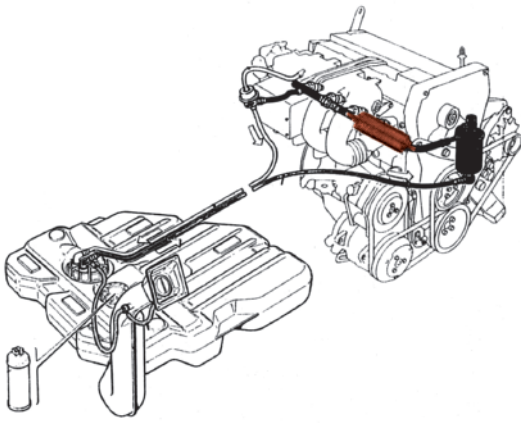
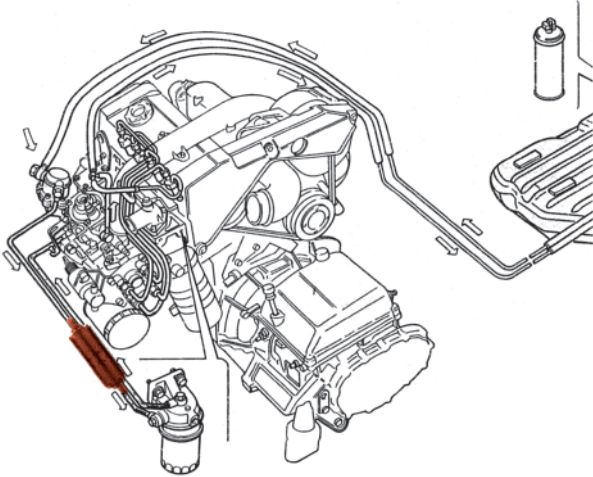
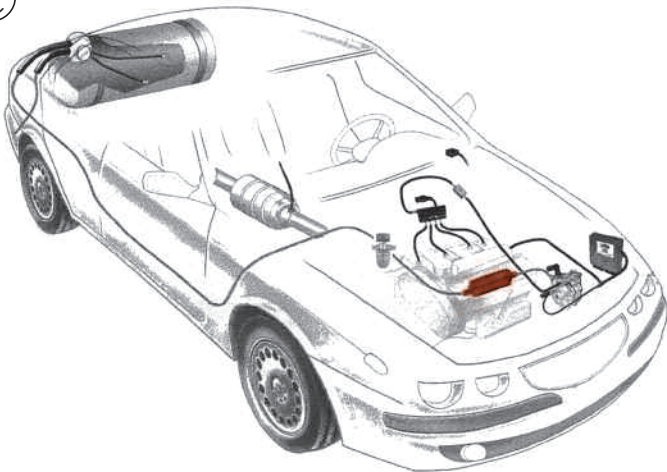

**A****B****C**

## Installation

The cartridge "SUPER CATALYZER" must be installed:

**A** In the petrol engines between the fuel pump and the carburettor or the injection system.

**B** In the diesel engines between the fuel pump and the diesel filter in the models with pump, after diesel filter in the models with injectors pump.

**C** In the gas engines between the tank and the expansion tank, near the last one.

- If the feeding system consists of two or more fuel pumps and several fuel filtering, the SUPER CATALYZER must be always installed before last diesel filter.

- In vehicles or ships with a re-circulating feeding, the treated fuel not combusted comes back in the tank priming the phenomenon of pre-treatment that remains permanent also in case of fuel staying in the tank indefinitely.

This treatment, previous and curative, acts on slime making, condensates and microbes (caused by fuel deterioration inactive for long-time) through the progressive dissolution of deposits in tanks, filters and feeding tubes.

## Warranty

According to the rules, the Laws and the International Right, except for breaches or malfunctions caused by a not corrected manipulation of the SUPER CATALYZER, hits, openings with consequent interruptions of the magnetic field.



**vosges** <sup>®</sup> <sup>TM</sup>

**Future Technology**

VOSGES di Moreno Beggio  
Via Roma, 133 - 36040 TORRI DI QUARTESOLO - Vicenza  
Tel. +39 0444 387119 r.a. - Fax +39 0444 264228  
www.vosges-italia.it - E-mail: estero@vosges-italia.it



**super catalyzer** <sup>®</sup> <sup>TM</sup>



**Systems equipped with the SUPER CATALYZER are our best guarantee. Contact us without any obligation on your behalf.**